

WARNING



Do not use the stacker before reading and understanding this operating instructions.

NOTE!

Keep for future reference.

ISO9001
ISO14001



**Operating Instructions / Parts List
HTF-G ELECTRIC PLATFORM**

日期: 2013.8.22

ATTENTION:

1. Environmentally hazardous waste, such as batteries and electronics, will have a negative effect on the environment, or health, if handled incorrectly.
2. The waste packages should be sorted and put into solid dustbins according to the materials and be collected disposal by local special environment protection bureau. To avoid pollution, it's forbidden to throw away the wastes randomly.
3. To avoid leaking during the use of the products, the user should prepare some absorbable materials (scraps of wooden or dry duster cloth) to absorb the leaking oil in time. To avoid second pollution to the environment, the used absorbable materials should be handed in to special departments in terms of local authorities.

NOBUFT 诺力

NOTE: All of the information reported herein is based on data available at the moment of printing. We reserve the right to modify our own products at any moment without notice and incurring in any sanction. So, it is suggested to always verify possible updates.

Welcome to use our electrical lift table. This lift table is made of high quality steel and is designed to give a durable, reliable and easy to use. For your safety and correct operation, please carefully read this instruction and warnings on the lift table before using it.

1. SPECIFICATIONS

Capacity	kg	1000
Lifting height	mm	840
Min.height	mm	80~85
Dimension of the table	mm	Length 1450 * Width 1140
Lifting speed	S	18
Lower speed	S	15
Pump electric current	L/min	3
Oil tank	L	3
Pump station		AC3x380V, 750W
Net Weight	Kg	250

2. SAFETY GUIDANCE

- 2.1 Operator should read all warning signs on the truck and instructions here before using it.
- 2.2 Do not put foot and hand under the scissors, injury could happen.
- 2.3 Do not enter under table.
- 2.4 Do not overload.
- 2.5 Do not use it on slope, lift table may become uncontrollable and creat danger.
- 2.6 Do not lift persons. People could fall down and suffer severe injury.
- 2.7 Do not side or end load .Load must be distributed on at least 80% of the table area.
- 2.8 The table should be maintained by the professional operator
- 2.9 Keep watching the condition of load, stop operating lift table if load becomes unstable.
- 2.10 Check and maintain the lift table regularly.
- 2.11 Do not use the lift table continuously, the pump station would be damaged.
- 2.12 Stop operating the lift table if the temperature of the oil is too high.
- 2.13 The table should be lowered to the bottom if the lift table is not used.

3. CONTROL PANEL

Four switches

3.1 Emergency switch

When you press down this switch, it will switch off the power, and then you turn it clockwise, it will switch on the power.

3.2 Lifting switch

When you press down this switch, the table will lift; when you loose your hand, the table will stop lifting.

3.3 Lowering switch

When you press down this switch, the table will be lowering; when you loose your hand, the table will stop lowering.

3.4 Replacement switch

The table can not lift or lower when the switch of safety protection frame starts. When you press down the Lifting switch, the table will be lifting, press down this switch the table will be lowering.

4. MAINTENCE

4.1 Hydraulic oil

Please check the oil level every six months. The oil can be hydraulic oil: ISO VG 32 (GB11118-89), its viscosity should be 32cSt at 40°C, total volume is about 4.0lt.

4.2 Daily check and maintenance

It is necessary to check daily. Special attention should be paid to the rollers, the axles, as thread, rags, etc., it may block the rollers; the scissors and the table should be checked, they may be deformed; the forks should be unloaded and lowered in the lowest position when the job is over.

4.3 Lubrication

Use motor oil or grease to lubricate all movable parts.

5. TROUBLES SHOOTING

No	TROUBLE	CLAUSE	FIXING METHODS
1	The table can not be up the Max. height	-The hydraulic oil is not enough. -The position of the travel switch.	-Pour in the oil. -Adjust the position of travel switch.
2	The table can not lift	-Without hydraulic oil. -Electromagnetic valve can not work.	-Pour in the oil -Change the electromagnetic valve
3	The motor can not run	-The emergency switch is turned off. -The connection of electrical wire is loose. -The contactor of DC motor is damaged.	-Turn the emergency switch clockwise. -Tight it; -Replace it with a new one.
4	The forks can not descend	-The piston rod or mast is deformed resulting from partial loading slanting to one side or over-loading. -The fork was kept in the high position for long time, which cause piston rod bared to arise in rusting and jamming of the rod. -The release valve of pump cannot work because of abrasion.	-Replace with new one -Keeping the fork in the lowest position if not using, and pay more attention to lubricate the piston rod. -Replace with new one.
5	Leaks	-Sealing parts worn or damaged. -Some parts cracked.	- Replace with new one. - Replace with new one.
6	The fork descends without the release valve worked	-The impurities in the oil cause the release valve to be unable to close tight. -Sealing parts worn or damaged. -The release valve is damaged.	- Replace with new one. - Replace with new one. - Replace with new one.

NOTE: Do not attempt to repair the truck unless you are trained and authorized.

6. ELECTRICAL SYSTEM

6.1 CIRCUIT DIAGRAM

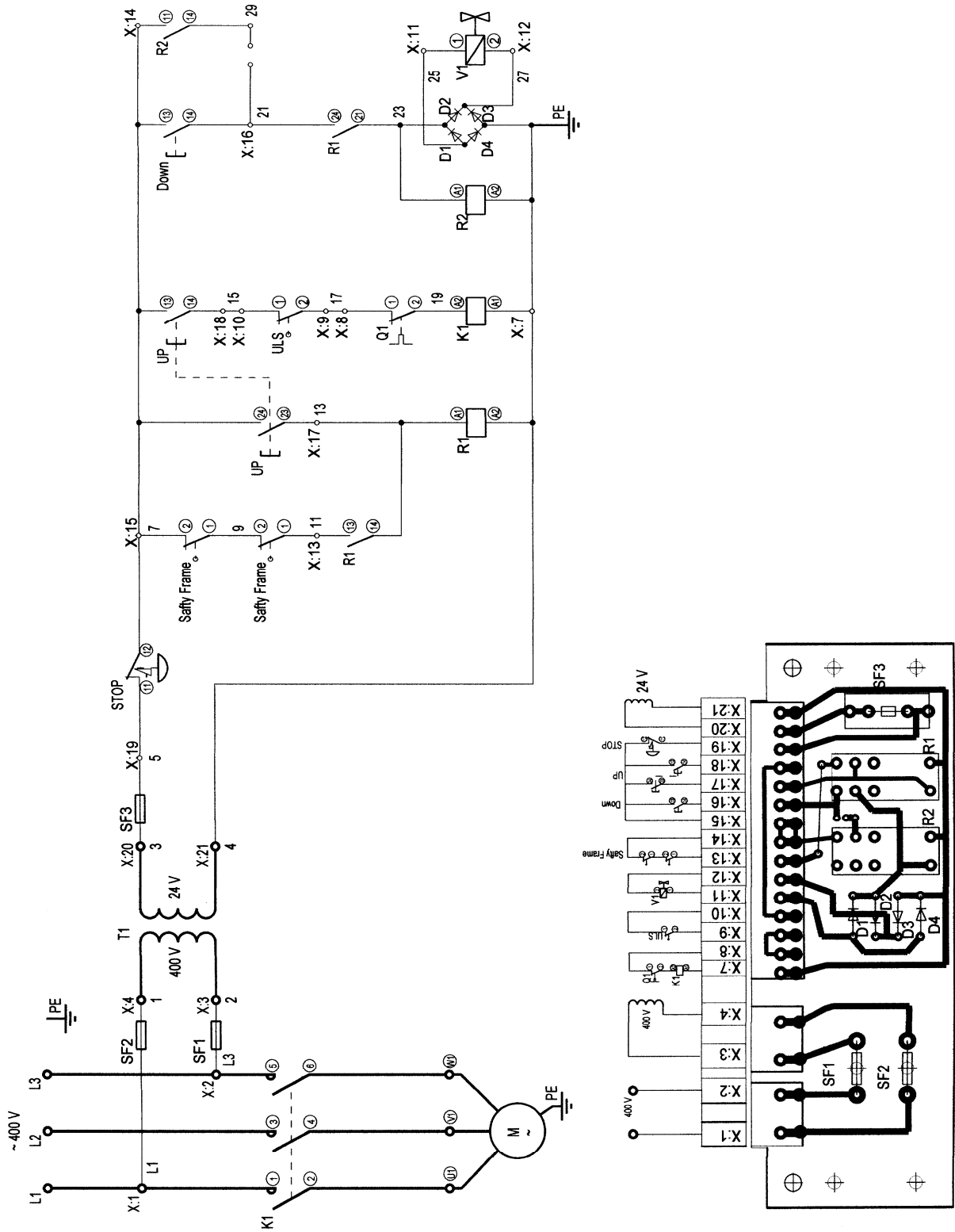

6.2 CONNECTION DIAGRAM

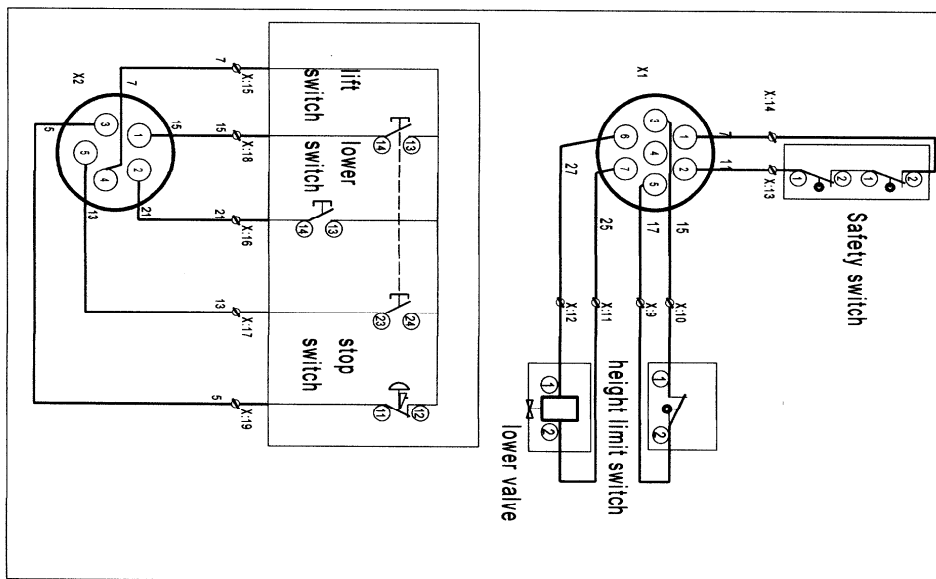
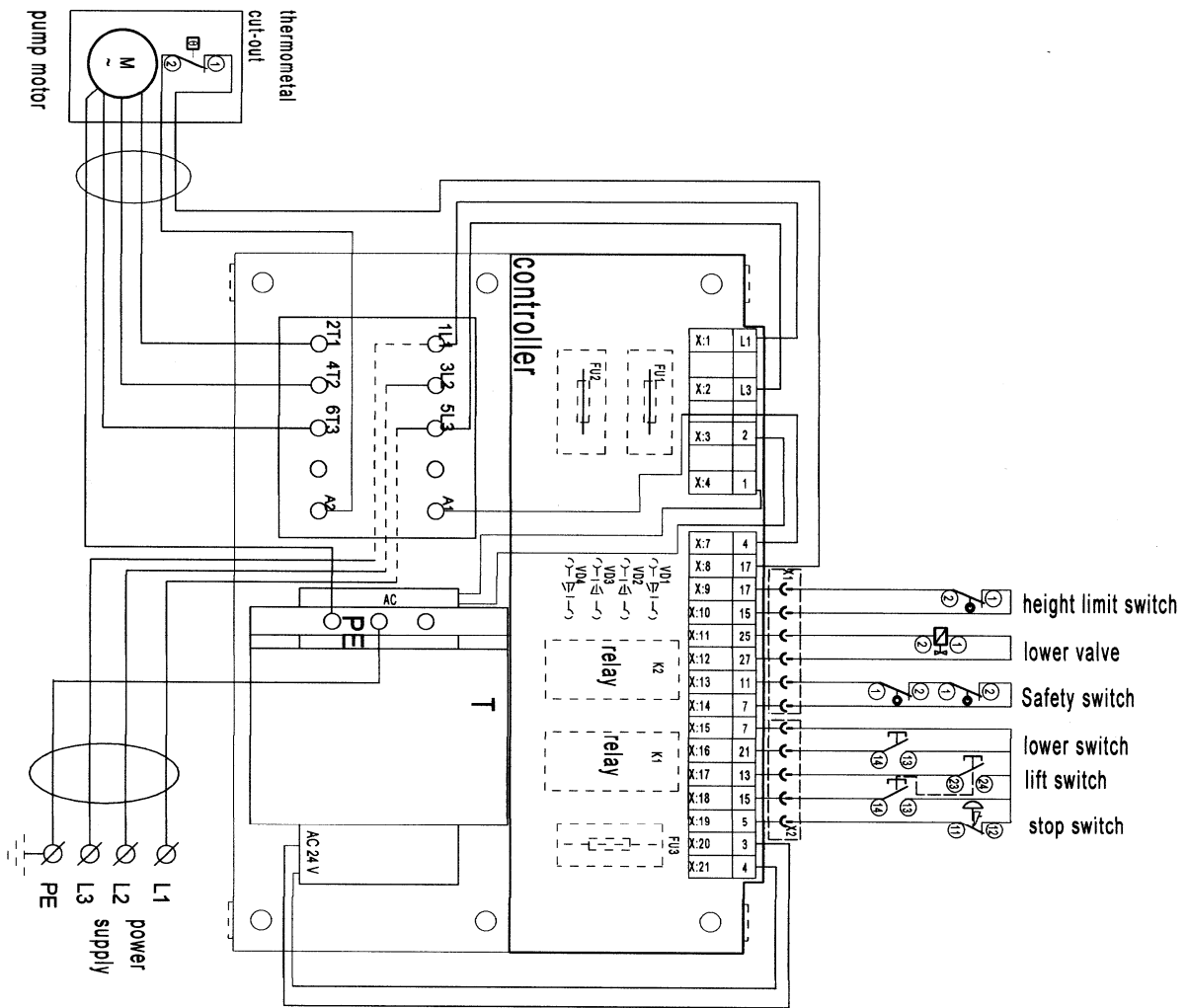

7. Hydraulic System

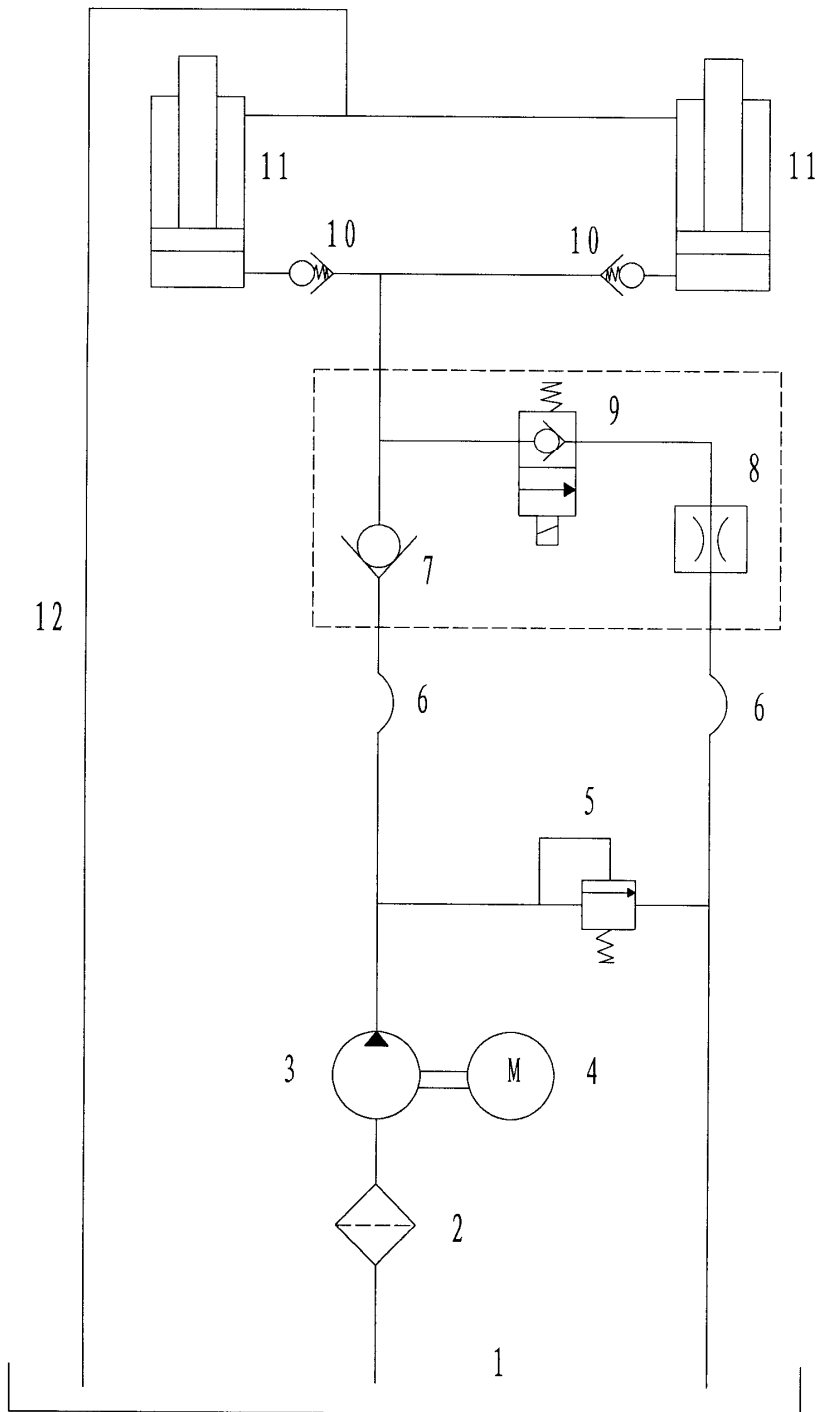

- 1) Tank
- 2) Filter
- 3) Pump
- 4) Motor
- 5) Relief Valve
- 6) Pipe
- 7) Check Valve
- 8) Throttle Valve
- 9) Solenoid Valve
- 10) Fuse Valve
- 11) Cylinder
- 12) Pipe

8. Parts List

8.1 PART LIST ELECTRIC PLATFORM

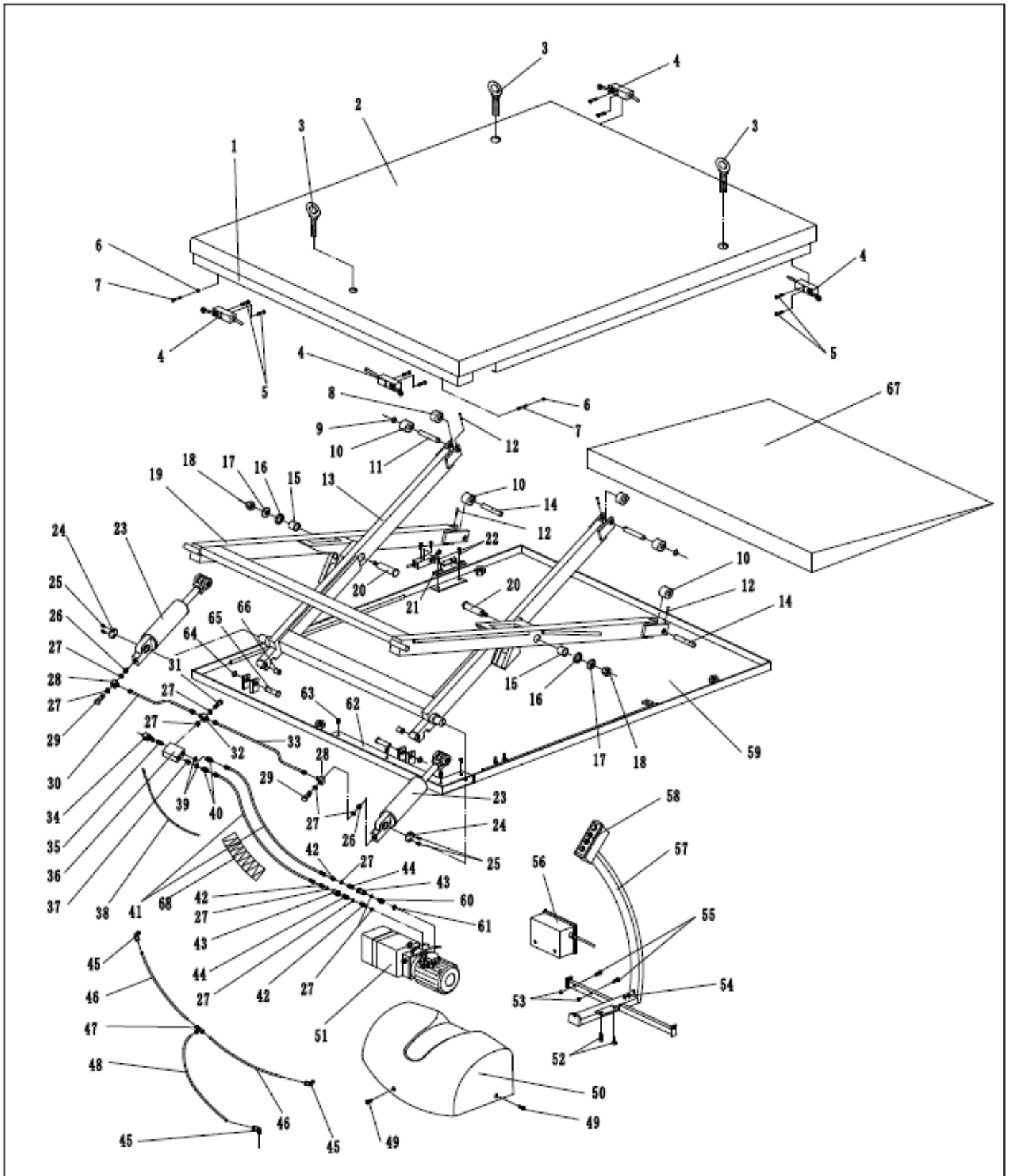

PART LIST ELECTRIC PLATFORM

No	Description	Qty.	No	Description	Qty.
1	Safety Border	1	36	Valve Plank	1
2	Table	1	37	unilateralism Valve	1
3	Bolt	3	38	cable	
4	Microswitch	4	39	Seal Washer	3
5	Bolt	8	40	Nipples M-M1/4-3/8	2
6	Nut	2	41	1/4 L=3000 pipe	2
7	Bolt	2	42	Nipples M1/4	3
8	Roller	2	43	Celerity tie-in	2
9	Retaining Ring	2	44	Celerity tie-in	2
10	Roller	4	45	curve	3
11	Shaft	2	46	pipe	2
12	Elastic Pin	4	47	Joint	1
13	Inside Fork Arm	1	48	pipe	1
14	Shaft	2	49	Bolt	3
15	Bushing	2	50	hood	1
16	Washer	2	51	pump	1
17	Washer	2	52	Bolt	2
18	Nut	2	53	Nut	2
19	Outside Fork Arm	1	54	Bolt	2
20	Shaft	2	55	Bolt	2
21	Connect Plank	1	56	chopper	1
22	Bolt	2	57	bracket	1
23	Cylinder	2	58	Control switch	1
24	Washer	2	59	Bottom plank	1
25	Bolt	4	60	Nipples M-M1/4-3/4	1
26	Safety Valve	2	61	O-Ring	1
27	Seal Washer	11	62	Cover board	1
28	Square Joint	2	63	screw	4
29	Bolt	2	64	Retaining Ring	2
30	pipe	1	65	Shaft	2
31	Bolt	1	66	Bushing	4
32	Joint	1	67	Slope	1
33	pipe	1	68	Hose protector	1
34	Electromagnetism Valve	1			
35	throttle Valve	1			

8.2 PART LIST OF THE CYLINDER

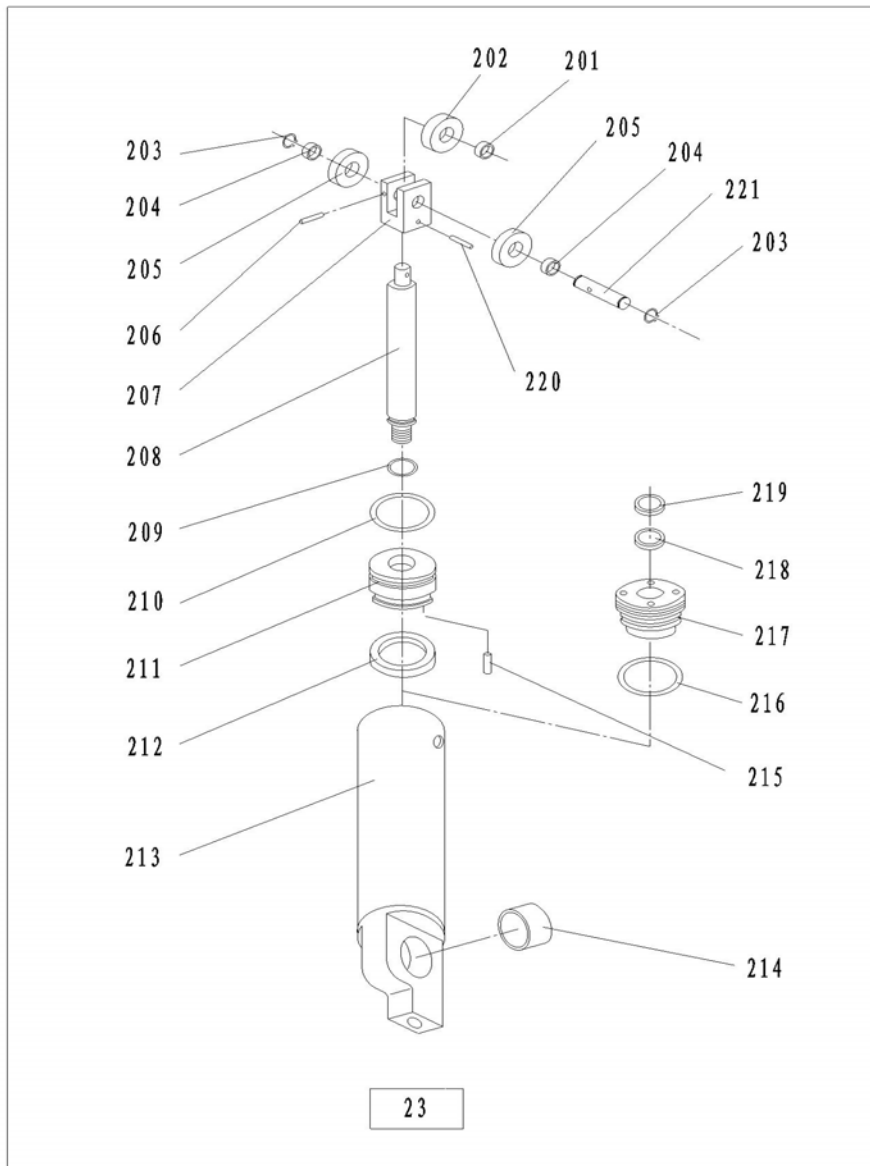

No	Description	Quantity	No	Description	Quantity
201	Bushing	2	212	Y-Seal	2
202	Roller	2	213	Housing	2
203	Retaining Ring	4	214	Bushing	2
204	Bushing	4	215	Pin	2
205	Roller	4	216	O-Ring	2
206	Elastic Pin	2	217	Cylinder Cap	2
207	Seat of Roller	2	218	Y-Seal	2
208	Piston Rod	2	219	Dust Ring	2
209	O-Ring	2	220	Elastic Pin	2
210	O-Ring	2	221	Shaft	2
211	Piston	2			